

BLODGETT[®]

BLODGETT[®]

BLODGETT[®]

BLODGETT[®]

BLODGETT[®]

BLODGETT[®]

BLODGETT[®]

BLODGETT[®]

BLODGETT[®]

BLODGETT[®]

BLODGETT[®]

BLODGETT[®]

BCH-G
GAS CABINET BASED BRAISING PAN WITH
HEAVY DUTY HYDRAULIC TILT
INSTALLATION – OPERATION – MAINTENANCE



BLODGETT OVEN COMPANY

www.blodgett.com

44 Lakeside Avenue, Burlington, Vermont 05401 USA Telephone (800) 331-5842, (802) 860-3700 Fax: (802) 864-0183

S00067 Rev A (5/04)

IMPORTANT NOTES FOR INSTALLATION AND OPERATION

It is recommended that this manual be read thoroughly and that all instructions be followed carefully. This manual should be retained for future reference.



This is the safety alert symbol. It is used to alert you to potential personal injury hazards. Obey all safety messages that follow this symbol to avoid possible injury or death.



FOR YOUR SAFETY: Do not store or use gasoline or other flammable vapors or liquids in the vicinity of this or any other appliance.

PURCHASER: Instructions to be followed in the event that the operator of this appliance smells gas must be posted in a prominent location. This information shall be obtained by consulting the local gas supplier.

The appliance area must be kept free and clear of combustibles.

Do not obstruct the flow of combustion and ventilation air.

Adequate clearances must be maintained for safe and proper operation.



WARNING: Improper installation, operation, adjustment, alteration, service or maintenance can cause property damage, injury or death. Read the installation, operating and maintenance instructions thoroughly before installing, operating or servicing this equipment.



Do not attempt to operate this unit in the event of power failure.

Intended for commercial use only. Not for household use.

TABLE OF CONTENTS

DESCRIPTION	PAGE
1.0 Important Notes for Installation and Operation	2
2.0 Service Connections	4
3.0 Installation Instructions	5
4.0 Operating Instructions	8
5.0 Cleaning Instructions	11
6.0 Cooking Guidelines	12
7.0 Maintenance.....	16
8.0 Troubleshooting	18
Material Safety Data Sheet	21

2.0 SERVICE CONNECTIONS

-  Supply gas through 3/4" pipe. A gas shut-off valve must be installed in supply piping convenient and adjacent to appliance.
-  Unless otherwise specified, Field Wire Electrical Connection to be 120 Volts, 60 Hertz single phase with grounding wire.

GAS SUPPLY

MODEL	BTU/HR.	kW/HR.	SUPPLY PRESSURE (W.C.)		EQUIPMENT CLEARANCE	
			Natural	Propane	LEFT	RIGHT
BCH-30G	80,000	23.4	6"-14" [152-356mm]	11"-14" [279-356mm]	3.0" [76 mm]	3.0" [76 mm]
BCH-40G	100,000	29.3			6.0" [152 mm]	

DIMENSIONS

MODEL	CAPACITY	UNITS	A	B	C	D	E	F
BCH-30G	30 gallons	inches	42.5	74.0	30.0	36.0	14.0	33.5
	114 litres	mm	1079	1880	762	914	356	851
BCH-40G	40 gallons	inches	44.0	74.0	42.0	48.0	19.0	43.5
	152 litres	mm	1118	1880	1067	1219	483	1105

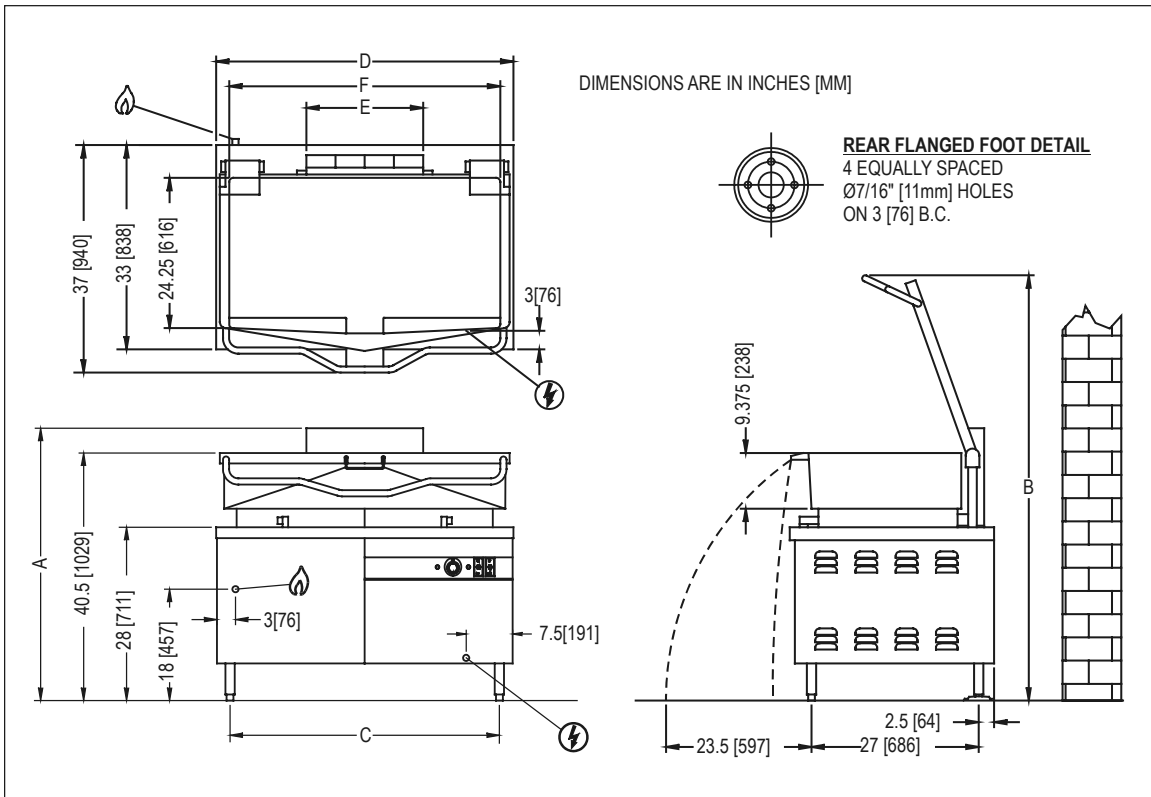

3.0 INSTALLATION INSTRUCTIONS

UNPACKING

Immediately after unpacking, check for possible shipping damage. If the tilting braising pan is found to be damaged, save the packaging material and contact the carrier within 15 days of delivery.

Before installing, verify that the electrical service agrees with the specifications on the rating plate located on the left side panel as you face the front of the braising pan. If the supply and equipment requirements do not agree, contact your dealer or Blodgett

LOCATION

The installation location must allow adequate clearances for servicing and proper operation.

An exhaust system and ventilation hood should be located directly above the appliance to exhaust combustion gases generated by the unit.

Appliance is intended for use on noncombustible floors. Minimum clearance from combustible and noncombustible floor construction, 3" (76 mm) on sides and 6" (152 mm) from back.

INSTALLATION CODES AND STANDARDS

Installation must conform with local codes, or in the absence of local codes, with the *National Fuel Gas Code, ANSI Z223.1/NFPA 54*, or the *Natural Gas and Propane Installation Code, CSA B149.1*, as applicable.

1. The appliance and its individual shut off valve must be disconnected from the gas supply piping system during any pressure testing of that system at pressures in excess of ½ psi (3.5 kPa).
2. The appliance must be isolated from the gas supply piping system by closing its individual manual shut off valve during any pressure testing of the gas supply piping system at test pressures equal to or less than ½ psi (3.5 kPa).

Electrical grounding must be provided in accordance with local codes, or in the absence of local codes, with the National Electrical Code, ANSI/NFPA 70, or the Canadian Electrical Code, CSA C22.2, as applicable.

ANSI/NFPA 96 - (latest edition), "Standard for Ventilation and Fire Protection of Commercial Cooking Operations," available from the National Fire Protection Association, Batterymarch Park, Quincy, MA, USA, 02269.

3.0 INSTALLATION INSTRUCTIONS (Continued)

LEVELLING AND ANCHORING TILTING BRAISING PAN

1. Place tilting braising pan in the installation position.
2. Place a carpenter's level on top of the braising pan and turn the adjustable feet to level braising pan side-to-side and front-to-back.
3. Mark hole locations on the floor through the anchoring holes provided in the rear flanged adjustable feet.
4. Remove tilting braising pan from installation position and drill holes in locations marked on the floor. (See installation diagram on page 4.) Insert proper anchoring devices (not supplied).
5. Place tilting braising pan back in the installation position.
6. Place carpenter's level on top of braising pan and re-level side-to-side and front to back.
7. Bolt and anchor tilting braising pan securely to the floor.
8. Seal bolts and flanged feet with silastic or equivalent compound.

GAS CONNECTIONS

All gas supply connections and any pipe joint compound used must be resistant to the action of propane gases.

Connect gas supply to the appliance. The gas supply line must be at least equivalent of 3/4" iron pipe with an incoming pressure of 7" - 14" W.C. (Water Column) for natural gas or 11" - 14" W.C. (Water Column) for propane gas. Make sure the pipes are clean and free of obstructions, dirt and piping compound.

Codes require that a gas shutoff valve be installed in the gas line ahead of the tilting braising pan. Natural gas and propane gas skillets are equipped with fixed orifices and no adjustment is necessary. Gas burner manifold is set at 3.5" W.C. (Water Column) for natural gas, and 10" W.C. (Water Column) for propane gas.

After piping has been checked for leaks, all piping receiving gas should be fully purged to remove air.



WARNING: Never use an open flame to check for gas leaks. Check all connections for leaks using soapy water before use.

NOTICE: If this equipment is being installed at over 2,000 feet altitude and was not so specified on order, contact service department. Failure to install with proper orifice sizing may void the warranty.



CAUTION: The pipe thread compound used when installing pipes must be a type that is resistant to the action of liquified petroleum or propane gases.

ELECTRICAL CONNECTIONS



WARNING: Do not connect the appliance to the electrical supply until after the gas connection has been made.



WARNING: ELECTRICAL GROUNDING INSTRUCTIONS
This appliance is equipped with a three-prong (grounding) plug for your protection against shock hazard and should be plugged directly into a properly grounded three-prong receptacle. Do not cut or remove the grounding prong from this plug. (120V units only).

The wiring compartment is located behind the control panel. For units operated on electrical supply other than 120 volts, remove the wiring compartment cover and make electrical connections per the wiring diagram located inside the control housing cover panel. The braising pan must be grounded in accordance with requirements of the National Electrical Code or applicable local code.

Replace wiring compartment cover.

4.0 OPERATING INSTRUCTIONS



WARNING: The tilting braising pan and its parts are hot. Use care when operating, cleaning and servicing the tilting braising pan.

BEFORE FIRST USE

Using a non-corrosive, grease-dissolving commercial cleaner, clean the protective metal oils from all surface parts and the interior of the tilting braising pan. Follow the cleaner manufacturer's directions. Rinse thoroughly and drain the pan. Wipe dry with a soft clean cloth.

CONTROLS:

- TILT SWITCH -** Push up to raise tilting braising pan; push down to lower tilting braising pan.
- POWER SWITCH -** Turns power on to the lift motor. Note: it is not necessary to have the power on when using the braising pan. Turn power on only when you intend to operate the tilt feature. This will save energy as well as prevent the motor from overheating.
- AMBER LIGHT -** Will light when the power is turned on to the lift motor.
- THERMOSTAT-** When turned on, will initiate the electronic ignition system and maintain the set temperature. Temperature settings range from 100°F (40°C) to 450°F (230°C).
- RED TEMPERATURE LIGHT -** Will light when burners are supplying heat to the tilting braising pan.

4.0 OPERATING INSTRUCTIONS (Continued)

START UP PROCEDURE

1. Open the manual gas shut-off valve located inside cabinet on left side when facing the front of the unit.
2. Ensure that the skillet pan is in the down or horizontal position.
3. Set the thermostat dial to the desired setting. The red “TEMPERATURE” pilot will be on until the desired setting has been reached.
4. The green “IGNITION” pilot should remain on with the “TEMPERATURE” pilot, indicating normal ignition and operation. If the “IGNITION” pilot goes off while the “TEMPERATURE” pilot remains on, this indicates that the system has failed to ignite the burners. A five minute period of complete shut off is required before restarting;
5. When the skillet has reached the setting, both pilots will go off, indicating the unit has reached the set temperature and that the burners are off. The unit will cycle on and off to maintain the set temperature.
6. Turn the “THERMOSTAT” switch to “OFF” when the skillet is not in use and close the manual gas shut-off valve.



WARNING: In the event of main burner ignition failure, a 5 minute purge period must be observed prior to re-establishing ignition source.

DAILY SHUT DOWN PROCEDURE

1. To turn tilting braising pan of, turn THERMOSTAT dial to OFF.
2. To turn power to tilt motor OFF, turn power switch to OFF.
3. Close manual gas shut-off valve.

4.0 OPERATING INSTRUCTIONS (Continued)

TILTING THE BRAISING PAN

1. DO NOT try to tilt braising pan with lid down. Turn POWER switch on.
2. Make sure the receiving pan is in place.
3. To tilt braising pan, push and hold TILT SWITCH in the UP mode until desired pan position has been reached. The braising pan will empty when raised to the top tilt position.
4. When the braising pan is raised 5° or more, the gas supply will be turned off automatically. The braising pan will not operate when the pan is not in the horizontal or down position.
5. Food is poured through the removable strainer (Figure 2) into a food receiving pan positioned under the lip of the pouring spout (Figure 2).
6. To lower braising pan, push and hold TILT SWITCH in the DOWN mode.
7. When tilting mechanism is not in use, turn POWER switch off.

FIGURE 2

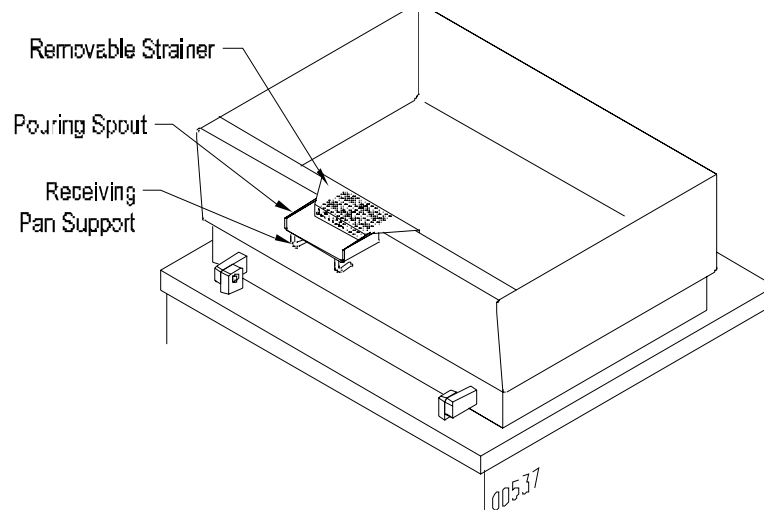

5.0 CLEANING INSTRUCTIONS



WARNING: Disconnect the power supply to the appliance before cleaning or servicing.

After each use, allow the tilting braising pan to cool before cleaning. Keep exposed cleanable areas of the tilting braising pan clean at all times. Do not get water in electrical box or on any electrical component.

1. Thoroughly wash pan, pouring spout, lid and exterior surfaces with mild detergent and warm water. If necessary, soak pan to remove food that is stuck to pan surface. Rinse thoroughly and wipe dry with a soft clean cloth.
2. Clean removable strainer and receiving pan support with mild detergent and warm water. Rinse thoroughly and wipe dry with a soft clean cloth.
3. Clean around burner air mixer and orifice if lint has accumulated.
4. Visually assure carry-over ports are unobstructed.

6.0 COOKING GUIDELINES

The guidelines given below are suggested quantities, temperature settings, and *estimated* numbers of orders per load and per hour. When two temperatures are given, the first is to start the product, and the second to finish the product.

The following temperatures should be used:

	<u>Temperature (°F)</u>
Simmering	200 Maximum
Sautéing	225 - 275
Searing	300 - 350
Frying	325 - 375
Grilling	350 - 450

<u>ITEM</u>	<u>PORTION</u>	<u>TEMP (F)</u>	<u>BATCH/HR</u>	<u>BCH-30G PER LOAD</u>		<u>BCH-40G PER LOAD</u>	
				<u>QTY</u>	<u>PORTIONS</u>	<u>QTY</u>	<u>PORTIONS</u>
BREAKFAST FOODS							
Bacon	3 slices	350	12	2 lbs.	10	3 lbs.	15
Eggs							
- Boiled-Hard	1 egg	225	5	50 eggs	50	75 eggs	75
- Boiled-Soft	1 egg	225	8	50 eggs	50	75 eggs	75
- Fried	1 egg	400	4	30 eggs	30	45 eggs	45
- Poached	1 egg	225	5	36 eggs	36	60 eggs	60
- Scrambled	1-1/2 eggs	300-200	1	18 gal.	720	28 gal.	1100
French Toast	3 slices	450	7	35 slices	12	50 slices	17
Regular Oatmeal	½ cup	250	2	20 lbs. (100 cups)	500	40 lbs. (200 cups)	1000
Pancakes	2 each	400	10	30 ea.	15	50 ea.	25
FISH							
Clams	1 pt.	400	10	10 qts.	20	15 qts.	30
Fish Cakes	2 - 3 oz.	400	5	70 - 3 oz.	35	110 - 3 oz.	55
Haddock Fillet	4 oz.	400	4	60 - 4 oz.	60	90 - 4 oz.	90
Halibut Steak	5 oz.	450	3	60 - 4 oz.	60	90 - 4 oz.	90
Lobster	1 - 1 lb.	350	4	20 - 1 lb.	20	30 - 1 lb.	30
Swordfish	5 oz.	450	3	50 - 5 oz.	50	75 - 5 oz.	75

<u>ITEM</u>	<u>PORTION</u>	<u>TEMP (F)</u>	<u>BATCH/HR</u>	<u>BCH-30G PER LOAD</u>		<u>BCH-40G PER LOAD</u>	
				<u>QTY</u>	<u>PORTIONS</u>	<u>QTY</u>	<u>PORTIONS</u>
SAUCES, GRAVIES, SOUPS							
Brown Gravy	1 oz.	350 - 200	2	18 gal.	2300	35 gal.	4500
Cream Sauce	2 oz.	250 - 175	1	18 gal.	1150	35 gal.	2250
Cream Soup	6 oz.	200	1	18 gal.	375	35 gal.	725
French Onion Soup	6 oz.	225	1	18 gal.	350	35 gal.	700
Meat Sauce	4 oz.	350 - 200	1	18 gal.	575	35 gal.	1100
VEGETABLES							
<u>CANNED</u>	3 oz.	400	6	30 lbs.	125	45 lbs.	200
<u>FRESH</u>							
Beans, Wax, Green	3 oz.	400	3	25 lbs.	125	50 lbs.	250
Beets	3 oz.	400	1	30 lbs.	125	60 lbs.	300
Broccoli	3 oz.	400	3	25 lbs.	125	40 lbs.	200
Cabbage	3 oz.	400	5	20 lbs.	80	30 lbs.	125
Carrots	3 oz.	400	2	35 lbs.	150	70 lbs.	300
Cauliflower	3 oz.	250	5	15 lbs.	75	25 lbs.	125
Corn	1 ear	400	8	50 ears	50	75 ears	75
Potatoes	3 oz.	400	2	40 lbs.	200	60 lbs.	300
Spinach	4 oz.	250	10	6 lbs.	25	9 lbs.	35
Turnips	4 oz.	400	2	20 lbs.	100	30 lbs.	150
<u>FROZEN</u>							
Beans, French Green	3 oz.	400	6	15 lbs.	60	22-1/2 lbs.	90
Lima Beans	3 oz.	250	4	15 lbs.	60	22-1/2 lbs.	90
Broccoli	3 oz.	400	8	12 lbs.	50	18 lbs.	75
Sliced Carrots	3 oz.	250	6	15 lbs.	60	22-1/2 lbs.	90
Small Whole Carrots	3 oz.	250	3	15 lbs.	50	22-1/2 lbs.	90
Corn	3 oz.	250	18	15 lbs.	50	22-1/2 lbs.	90
Small Whole Onions	3 oz.	250	7	15 lbs.	50	22-1/2 lbs.	90
Peas	3 oz.	400	10	15 lbs.	75	22-1/2 lbs.	110
Spinach	3 oz.	400	3	15 lbs.	75	22-1/2 lbs.	110

<u>ITEM</u>	<u>PORTION</u>	<u>TEMP (F)</u>	<u>BATCH/HR</u>	<u>BCH-30G PER LOAD</u>		<u>BCH-40G PER LOAD</u>	
				<u>QTY</u>	<u>PORTIONS</u>	<u>QTY</u>	<u>PORTIONS</u>
DESSERTS, PUDDINGS, SWEET SAUCES							
Butterscotch Sauce	1 oz.	200	1	18 gal.	2300	35 gal.	4500
Cherry Cobbler	3 oz.	200	1	18 gal.	750	35 gal.	1500
Chocolate Sauce	1 oz.	200	1	18 gal.	2300	35 gal.	4500
Cornstarch Pudding	4 oz.	200	1	18 gal.	575	35 gal.	1100
Fruit Gelatin	3 oz.	250	2	18 gal.	750	35 gal.	1500
MEAT-POULTRY							
Bacon	3 slices	350	12	2 lbs.	10	3 lbs.	15
<u>BEEF</u>							
Amer. Chop Suey	6 oz.	400 - 225	2	18 gal.	350	35 gal.	700
Beef Stew	8 oz.	300	-	18 gal.	280	35 gal.	560
Corned Beef Hash	5 oz.	400	5	16 lbs.	50	25 lbs.	75
Cheeseburger	3 oz.	300	12	7 lbs.	35	10 lbs.	50
Hamburger	3 oz.	300	15	7 lbs.	35	10 lbs.	50
Meatballs	1 oz.	400-225	3	12-1/2 lbs.	65	18 lbs.	100
Pot Roast	2 oz.	350-200		120 lbs.	500	180 lbs.	750
Salisbury Steak	5 oz.	400	3	16 lbs.	50	24 lbs.	75
Sirloin Steak	6 oz.	400	5	15 lbs.	40	22-1/2 lbs.	60
Swiss Steak	4 oz.	300-200	1	25 lbs.	110	40 lbs.	160
<u>CHICKEN</u>							
Pan Fried	2-1/4's	350	3	50 pieces	25	80 pieces	40
Whole	2 oz.	350-200		16 - 5 lbs.	200	24-5 lbs.	265
<u>FRANKFURTERS</u>							
Grilled	2 oz.	300	8	22 lbs.	176	33 lbs.	264
Boiled	2 oz.	250	12	16 lbs.	128	25 lbs.	200
<u>PORK</u>							
Ham Steak	3 oz.	400	8	10 lbs.	50	15 lbs.	75
Sausage Links	3 links	350	7	30 lbs.	120	45 lbs.	180
Pork Chops	5 oz.	350	4	15 lbs.	50	25 lbs.	75

<u>ITEM</u>	<u>PORTION</u>	<u>TEMP (F)</u>	<u>BATCH/HR</u>	<u>BCH-30G PER LOAD</u>		<u>BCH-40G PER LOAD</u>	
				<u>QTY</u>	<u>PORTIONS</u>	<u>QTY</u>	<u>PORTIONS</u>
MEAT-POULTRY (continued)							
<u>TURKEY</u>							
Off Carcass	2 oz.	400-200	–	3 26-30 lbs.	200	4 26-30 lbs.	275
On Carcass	2 oz.	400-200	–	4 16-20 lbs.	175	6 16-20 lbs.	265
MISCELLANEOUS							
Grilled Cheese Sandwich	1 sandwich	400	8	35 sandwiches	35	50 sand.	50
Macaroni & Cheese	8 oz.	200	2	18 gal.	300	35 gal.	525
Rice	4 oz.	350-225	1	20 lbs. raw	320	40 lbs. raw	650
Spaghetti	4 oz.	350-225	2	8 lbs. raw	200	12 lbs. raw	300

7.0 MAINTENANCE

NOTICE: Contact the factory, factory representative or local service company to perform maintenance and repairs.



WARNING: The tilting braising pan and its parts are hot. Use care when operating, cleaning and servicing the tilting braising pan.



WARNING: Disconnect the power supply to the appliance before cleaning or servicing.

HYDRAULIC SYSTEM

SERVICE

Set up regular schedule for checking the oil temperature, hydraulic hoses and keeping the equipment clean. A thick layer of dirt acts as an insulation and prevents the hydraulic system from getting rid of heat.

The hydraulic system has been adjusted and tested at the factory and no further adjustment should be needed. If the unit fails to operate properly, all service work must be performed by a qualified service agent.

1. Hot oil in the Hydraulic System is one of the primary causes of poor operation. When the tilt system is not in use turn POWER switch off.
2. Inspect hydraulic hoses for wear and aging.
3. Check that fluid levels are kept full.
4. To replace oil, fill through filler breather.
5. Use proper oil as specified by factory. TYPE: AWH32 or equivalent.
6. Check the cleanliness of the oil strainer inside the reservoir once per year. This item can be washed in clean Varsol.
7. Change the breather filter once per year.
8. Change the oil once every two years.

ADJUSTMENTS AND CONTROLS:

ADJUST PAN SPEED

There are three controls available on this power unit. The first is an adjustable relief valve mounted into the custom aluminum manifold block. The other two control the linear speed of the actuator.

RELIEF VALVE:

The relief valve is located underneath an aluminum hexagon cover on the side of the custom manifold block. This relief valve is factory set to 825 P.S.I. and locked and should not be adjusted.

If adjustments are necessary, remove the hexagon cover which will give access to the relief valve screw. With the pump running, and with a suitable flat blade style screwdriver, rotate the screw clockwise to increase pressure, and counter-clockwise to decrease pressure. While this operation is being carried out some oil will leak down the threads of the adjusting screw.

To obtain the pressure required, a pressure gauge will have to be located in the circuit. The best location is on the cylinder hose. To set the pressure, energize the solenoid to extend the cylinder fully and thus "deadhead" the system. The pressure can be set as indicated above. When adjustment is complete, replace the hexagon cover. This will seal the relief valve area. The actual factory set pressure is noted on the label and should not be exceeded as this affects the HP draw on the electric motor.

FLOW CONTROL:

There are two flow control valves mounted on the power unit and located on the solenoid valve subplate. The flow control valves will restrict the capacity of oil passing through them when the knurled knob is screwed in - in a clockwise direction. This action will reduce the linear speed of the cylinder. Turning the flow control valve adjustment in the opposite direction – counter-clockwise, will increase the speed of the cylinder. One flow control valve (right side) will allow adjustment of the extension speed (travel speed should be set at minimum 20 seconds), the other (left side) the retraction speed. (Retraction speed should be set at minimum 10 seconds).

IMPORTANT:

It should be noted that if the cylinder speed is restricted by the flow control valves, the balance of oil not delivered to the cylinder will go over the relief @ 825 P.S.I. which will cause unwanted heat in the reservoir.

8.0 TROUBLESHOOTING

- 1) BURNERS DO NOT COME ON:
 - a) Gas supply to unit is "OFF".
 - b) Manual shut off valve is "OFF".
 - c) Thermostat is not turned "ON".
 - d) Pan not in lowest position.
 - e) Ignition Module not functioning.
- 2) BURNERS PRODUCE CARBON DEPOSITS:
 - a) Wrong size orifices.
 - b) Burner air not adjusted properly.
 - c) Wrong gas supply.
 - d) Incorrect pressure at supply.
- 3) BRAISING PAN WILL NOT OPERATE (UP OR DOWN):
 - a) Motor power supply not "ON".
 - b) Defective UP/DOWN switch.
 - c) SEE TROUBLESHOOTING - HYDRAULICS.

TROUBLESHOOTING - HYDRAULICS:

- 1) DIRTY OIL:
 - a) Components not properly cleaned after servicing.
 - b) Inadequate screening in fill pipe.
 - c) Air breather left off.
 - d) Filter dirty or ruptured.
- 2) FOAMING OIL:
 - a) Return of tank line not below fluid level.
 - b) Fluid contamination.
 - c) Suction leak to pump.

3) MOISTURE IN OIL:

- a) Fill pipes left open.
- b) Moisture in container used to replace oil in tank.
- c) Extreme temperature differential.

4) OVERHEATING OF SYSTEM:

- a) Continuous operation at relief setting.
- b) Excessive slippage or internal leakage.
- c) Fluid viscosity too high or low.
- d) Hose I.D. too small causing high velocity.
- e) Improper air circulation around reservoir.
- f) System relief valve set too high.
- g) Power unit operating in direct sunlight or ambient temperature is too high.

5) PUMP MAKES EXCESSIVE NOISE:

- a) Check for vacuum leaks in suction line.
- b) Vacuum leak at pump shaft seal.
- c) Check alignment with drive mechanism. Misalignment will cause wear and subsequent high noise level operation.
- d) Relief valve set too high.
- e) Aeration of fluids in reservoir (return line above fluid level.)
- f) Worn cam ring, damaged gear, faulty bearing.
- g) Reversed rotation.
- h) Plugged lines.
- i) Oil viscosity too high or temperature too low.
- j) Loose or worn pump parts.
- k) Pump housing bolts loose or not properly torqued.

6) SOLENOID VALVES:

- a) Voltage too low.
- b) Short circuit, open connection.
- c) Wrong voltage.
- d) Foreign matter in fluid causing valves to stick or plug.

Proper Shipping Name: Hydraulic System Fluid, Other Than Petroleum
WHMIS Hazard: Not Controlled
TDG Hazard Class: Non-Hazardous
Hazard Number: Not applicable
Chemical Family: Mixture
Completed By: J. Pajak
Telephone Number: 1-416-763-4691
Facsimile Number: 1-416-763-3167
DUNS Number: 20-167-2573

SECTION II - HAZARDOUS COMPONENTS

<u>Material Description</u>	<u>CAS No.</u>	<u>Percent</u>	<u>Hazard</u>
-----------------------------	----------------	----------------	---------------

This product contains no known hazardous components under current OSHA, ACGIH, WHMIS or the IDL regulations.

SECTION III - PHYSICAL DATA

Boiling Point (Degree Fahrenheit) : >300
Specific Gravity (Water = 1) : 0.91
Vapour Pressure (mmHg) : <1
Evaporation Rate (BuAcr = 1) : <1
Vapour Density (Air = 1) : >1
Percent Volatile : Nil
Soluble in Water : Insoluble
pH Neat : Not Applicable
Appearance and Odour : Slightly hazy amber liquid with a bland odour.

SECTION IV - FIRE AND EXPLOSION HAZARD DATA

Flash Point (Degrees Fahrenheit) : 520
Method Used : C.O.C.
LEL : Not Determined
UEL : Not Determined
NFPA Classifications, Health : 1
Fire : 1
Reactivity : 0

Extinguishing Methods : Carbon dioxide, foam, dry chemical

Special Fire Fighting Instructions : None required

Unusual Fire and Explosion Hazards: None

SECTION V - HEALTH HAZARD INFORMATION

Threshold Limit Value (TLV) and Permissible Exposure Limit (PEL): See Section II - Hazardous Components

Primary Routes of Exposure - Eyes, skin, inhalation.

Chronic or Recurrent Effects: Unknown for this product.

Acute Effects:

Inhalation: No significant effects known.

Skin: May be a mild irritant on prolonged contact.

Eyes: Mild irritant

Ingestion: No significant effects known.

***** First Aid *****

Inhalation: Not applicable.

Skin: Wash with soap and water. Remove contaminated clothing and launder before reusing.

Eye: Flush with water for 15 minutes. Consult physician.

Ingestion: Induce vomiting. Give liquids. Consult physician. Product contains fatty acid ester.

Note to Physicians: No specific antidote known. Based on individual reactions of the patient, the physician's judgement should be used to control symptoms and clinical conditions.

SECTION VI - REACTIVITY DATA

Stability: Stable [X], Unstable []

Incompatibility (Materials to Avoid): Strong Oxidizers

Hazardous Decomposition Products: Thermal, Oxides of Carbon

Hazardous Polymerization: May Occur: [], Will Not Occur [X]

SECTION VII - SPILL OR LEAK PROCEDURES

Potential as a Pollutant: Not considered a pollutant if effective waste disposal methods are utilized. Keep out of sewers and streams.

Spill, Leak or Release: Apply dry absorbent material and sweep up.

Waste Disposal: Follow pertinent regulations for disposal. It is the responsibility of the product user to determine, at the time of disposal, whether a material containing the product or derived from the product should be classified as a hazardous waste (40 CFR 261.20-24).

SECTION VIII - SPECIAL PROTECTION INFORMATION

Respiratory Protection: Not required.

Ventilation: General workplace ventilation is satisfactory

Protective Gloves: Rubber if skin is sensitive.

Eye Protection: Safety goggles or safety glasses with side shields.

Other Protective Equipment: Eye wash and safety shower recommended.

SECTION IX - SPECIAL PRECAUTIONS

Storage and Handling: Keep containers closed when not in use. Avoid contact with strong oxidizers. Wash thoroughly after handling.

ADDITIONAL PRODUCT INFORMATION

Carcinogens as Defined By: NTP: None
IARC: None
OSHA: None

Cercla Reportable Quantity (lbs.): None

RCRA Hazardous Waste Number: Not Applicable

CEPA: All components of this product are listed on the Domestic Substances List (DSL) as encoded in the extract of the Canada Gazette, Part I.

SARA, Title III, Section 313: This product contains no toxic chemicals subject to the reporting requirements of Section 313 of Title III of the Superfund Amendments and Reauthorization Act of 1986 and 40 CFR part 372.

The information contained herein is based on data considered accurate. However, no warranty is expressed or implied regarding the accuracy or the translation of this data or the results to be obtained from the use thereof. Houghton Canada Inc. assumes no responsibility for personal injury or damage to users or third parties caused by the material. Such users assume all risks associated with